

HBJS



# 机械制图

# § 2-2 三视图的形成及其投影规律

HBJS

1. 三投影面体系的建立

2. 三视图的投影对应关系

3. 三视图与物体方位对应关系

4. 三视图的作图与读图

# § 2-2 三视图的形成及其投影规律

## 一、三投影面体系的建立

### 1、问题的提出

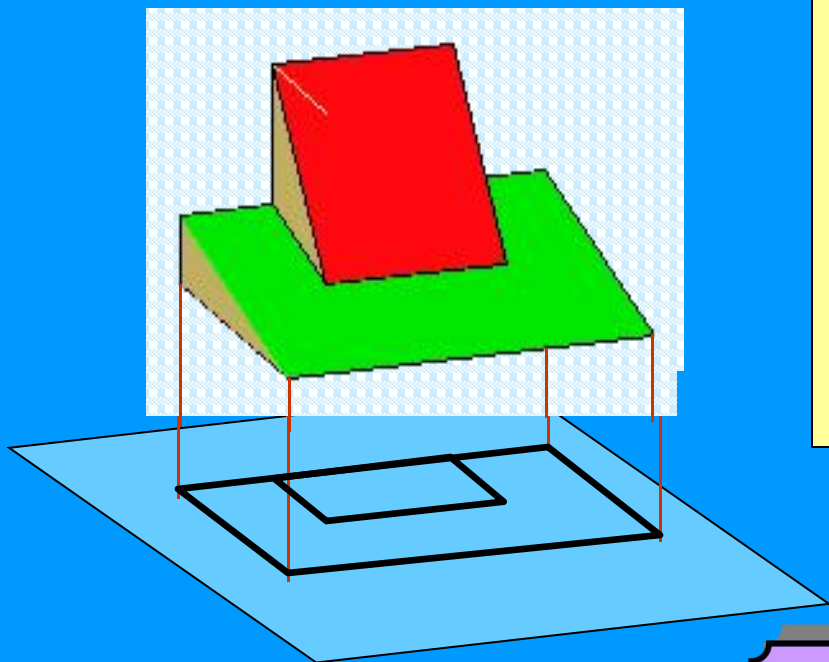

**结论：** 物体的一个投影不能唯一确定该物体的空间形状。

物体的单面投影

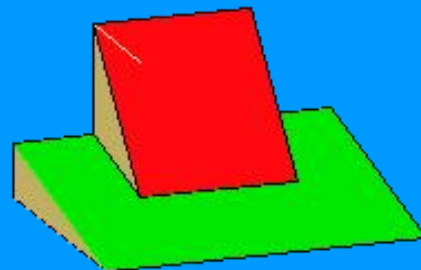
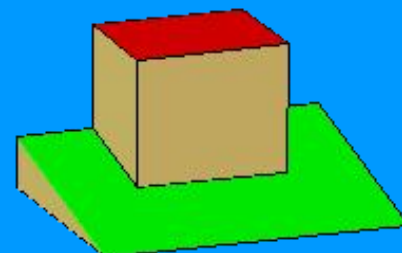
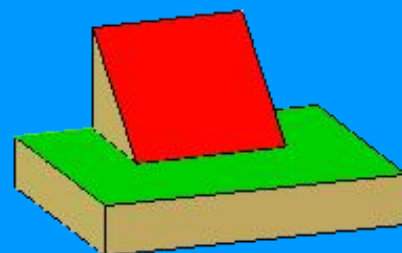
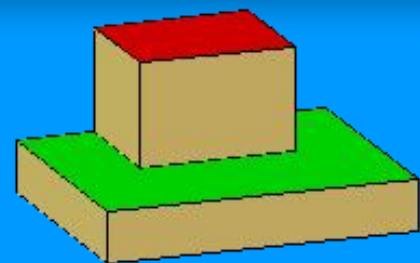

# § 2-2 三视图的形成及其投影规律

HBJS

## 2、两面投影图

能否唯一确定物体的空间形状？

不一定！

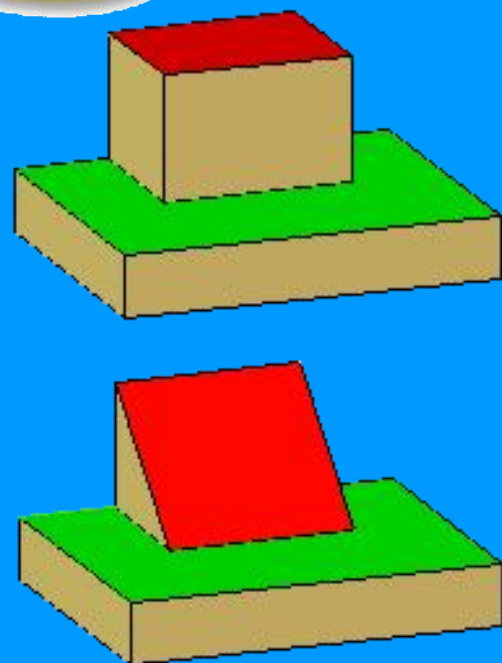
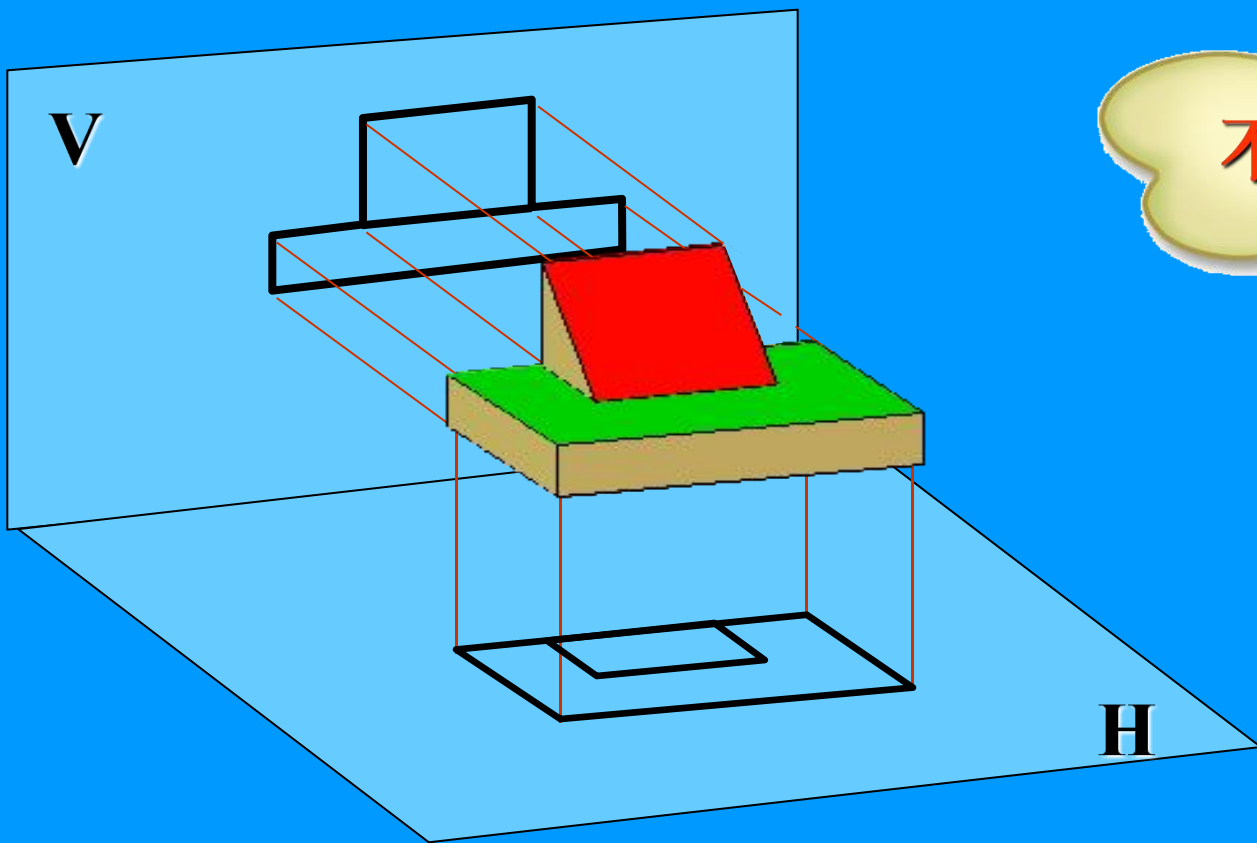

物体的两面投影

# § 2-2 三视图的形成及其投影规律

HBJS

## 3、三面投影图

是否唯一确定物体的空间形状？

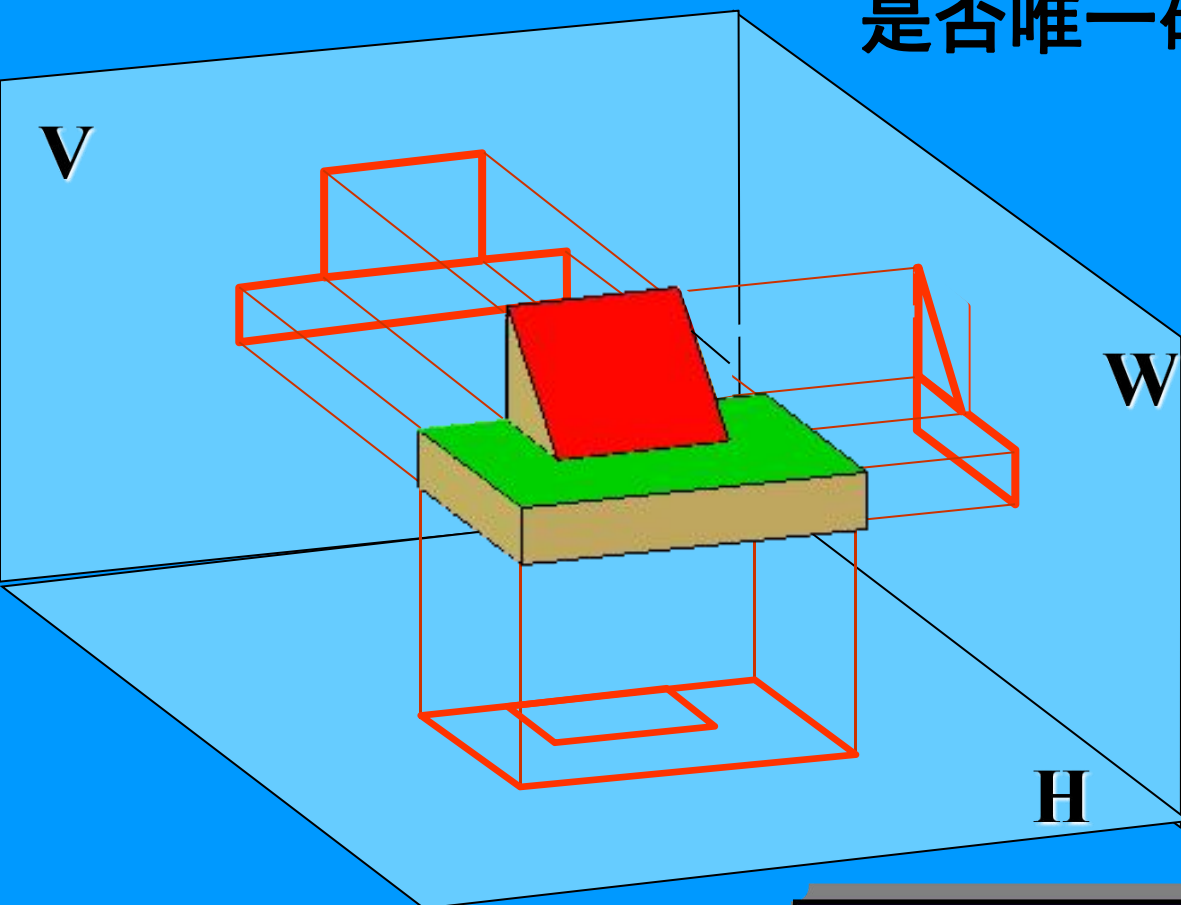

唯一确定！

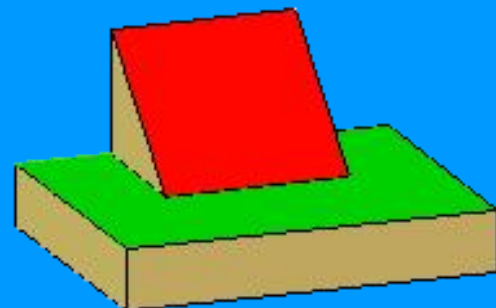
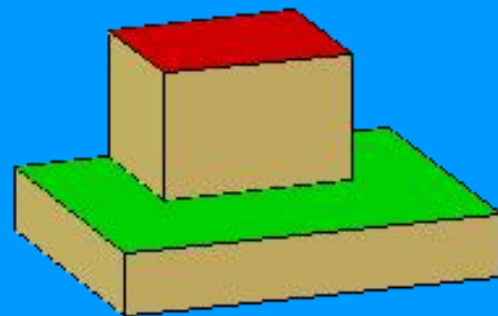

物体的三面投影

# § 2-2 三视图的形成及其投影规律

## 律

### 4、三投影面体系的建立

✂ 设立三个互相垂直的投影平面，构成三面投影体系。这三个平面将空间分为八个分角，(GB4458.1 - 84)规定：采用第一角投影法，

#### 三投影面体系建立过程

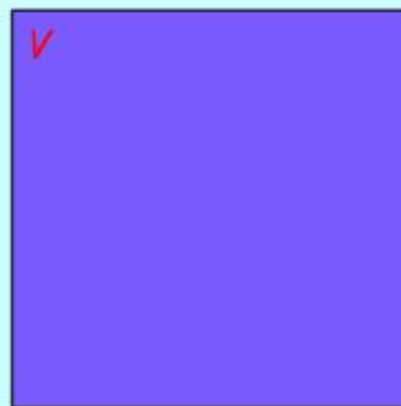
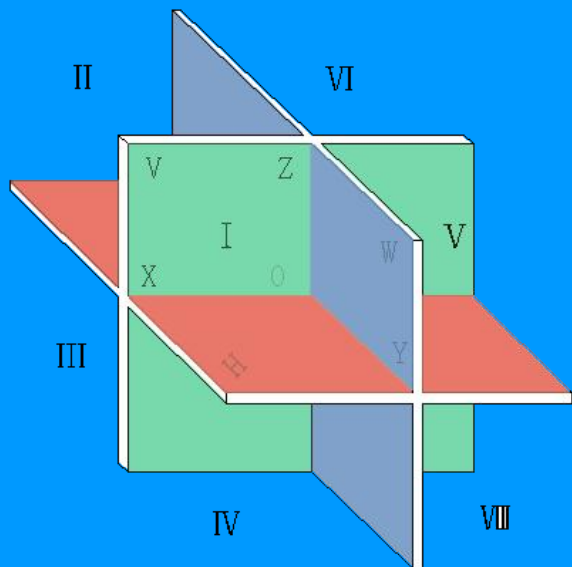

空间分为八个分角

# §2-2 三视图的形成及其投影规律

## 第一分角

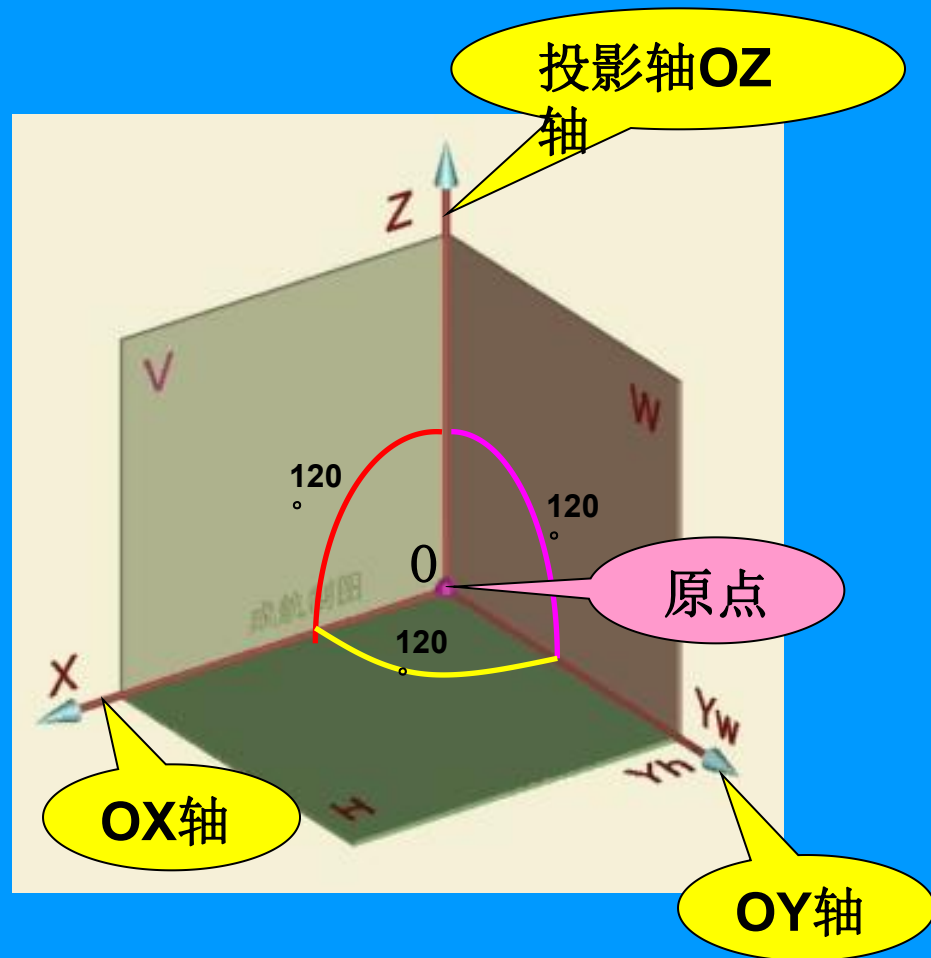
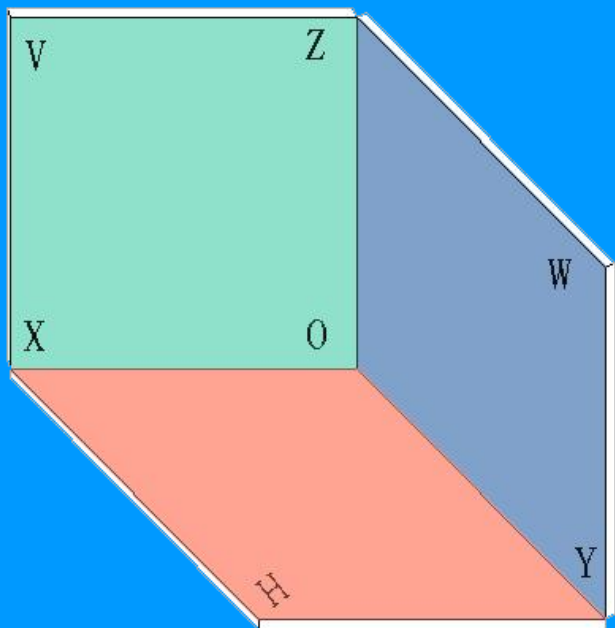

### 5、三视图的形成

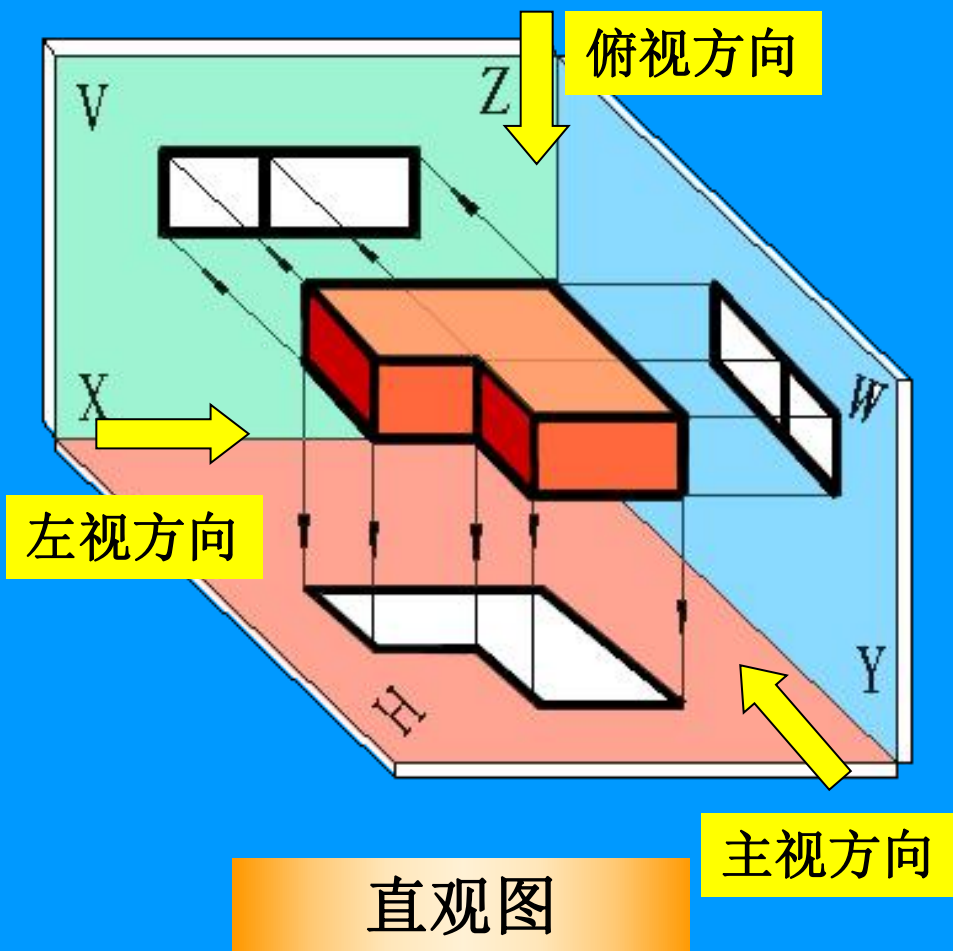

**主视图：**物体由前向后投影，在V面上得到的视图。

**俯视图：**物体由上向下投影，在H面上得到的视图。

**左视图：**物体由左向右投影，在W面上得到的视图

**三视图的名称**



## §2-2 三视图的形成及其投影规律

HBJS

### 投影体系的展开

- ★ 保持V投影面不动。
- ★ 将H投影面绕OX轴向下旋转 $90^\circ$ ，使H面与V面共面。
- ★ 将W投影面绕OZ轴向右旋转 $90^\circ$ ，使W面与V面共面。

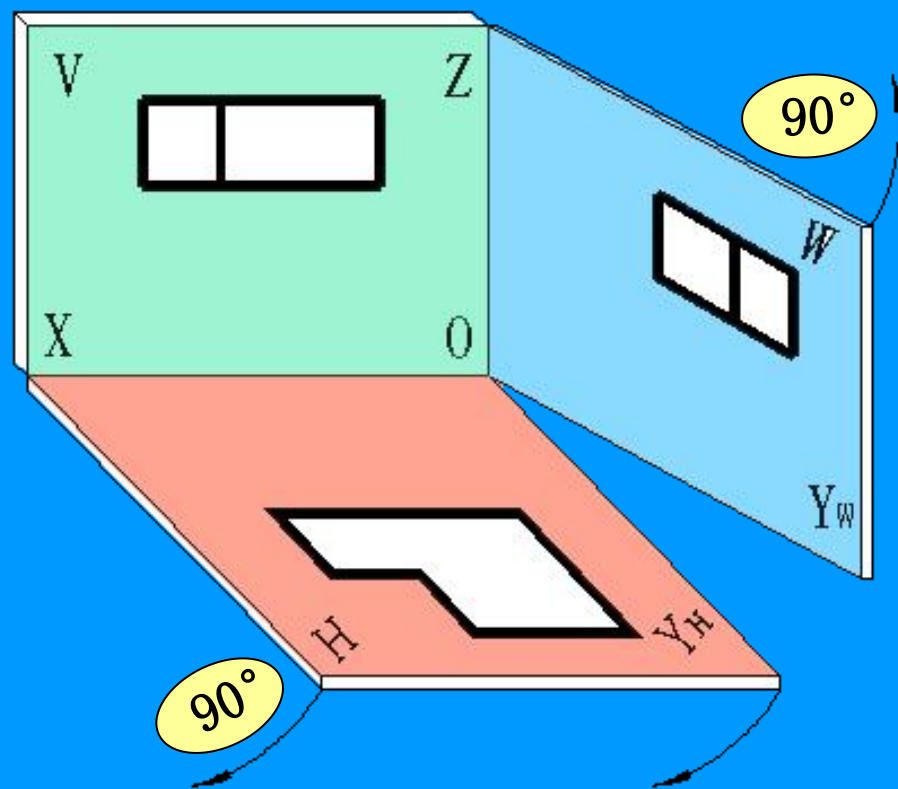

展开投影面

# § 2-2 三视图的形成及其投影规律

## 律

HBJS

展开后的三视图

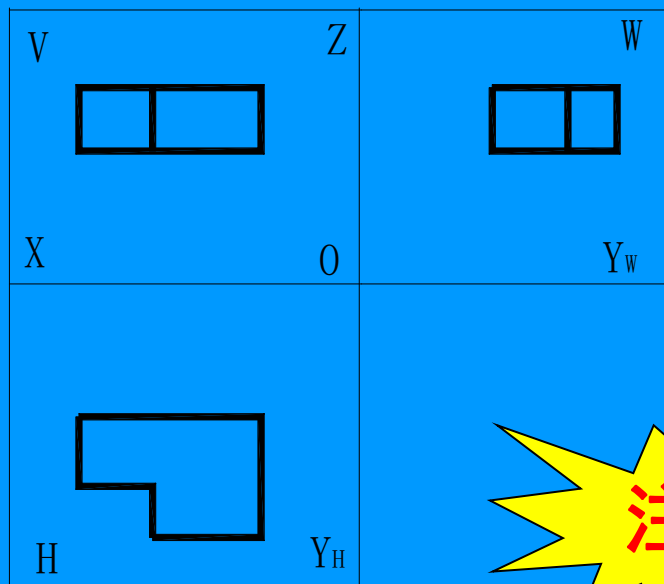

三视图

(主视图)



(左视图)



(俯视图)





去除投影

面边框即得：

三视图

**注意**

 在三投影面体系中摆放形体时，应使形体的多数表面(或主要表面)平行或垂直于投影面(即形体正放)。

 形体在三投影面体系中的位置一经选定，在投影过程中绝对不允许移动或变更。

# §2-2 三视图的形成及其投影规律

## 二、三视图的投影对应关系

### 1、三视图的位置关系

俯视 (产生H面投影)

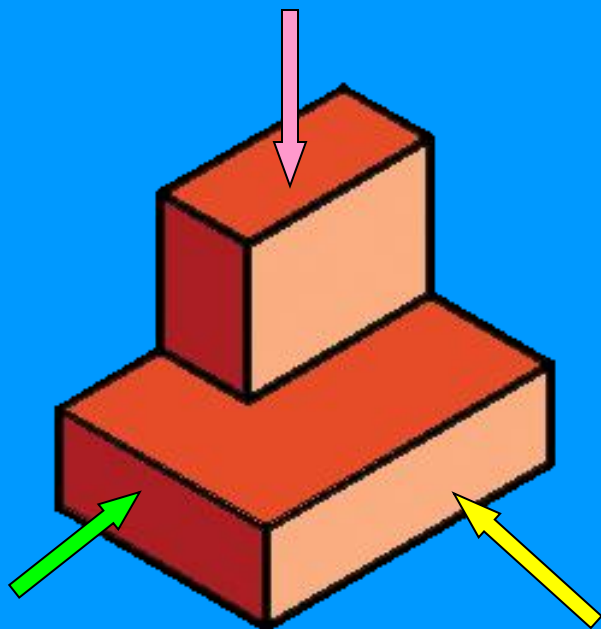

左视 (产生W面投影)      主视 (产生V面投影)

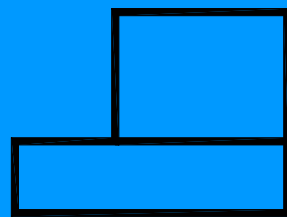

主视图 (V面)

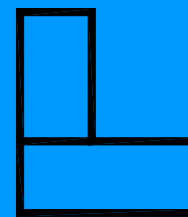

左视图 (W面)

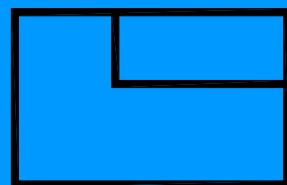

俯视图 (H面)

三视图的位置关系

# § 2-2 三视图的形成及其投影规律

## 律

HBJS

V 面投影(主视图)反映形体正面形状及其长度及高度;  
H 面投影(俯视图)反映形体上面形状及其长度及宽度;  
W 面投影(左视图)反映形体左侧面形状及其高度及宽度。  
系, 在一般情况下是不允许变动的。

## 2、三视图的度量关系

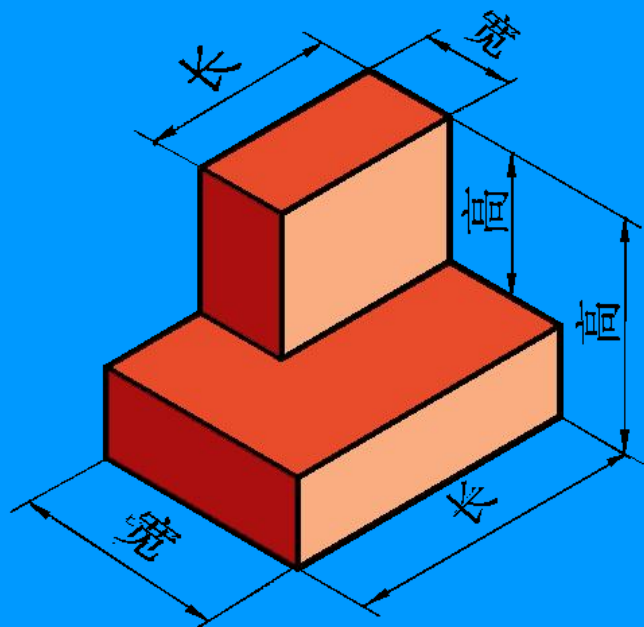

直观图

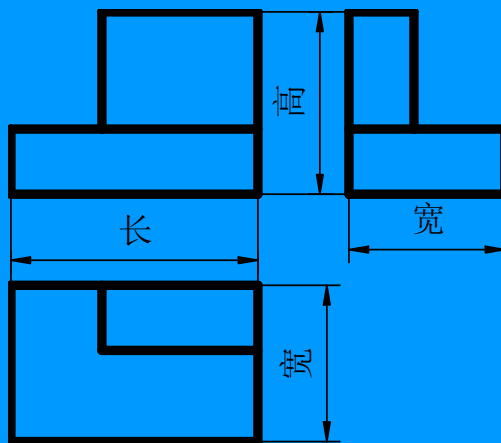

总体三等

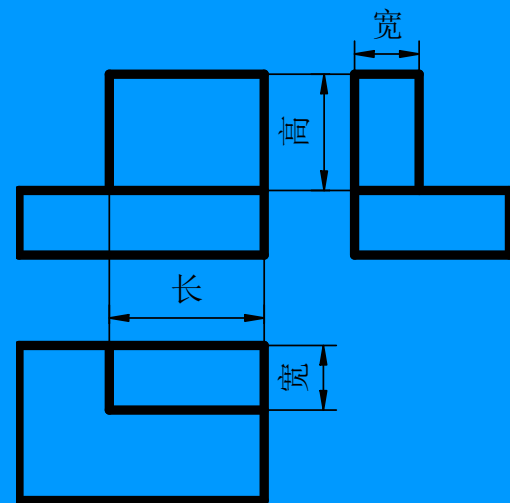

局部三等

# §2-2 三视图的形成及其投影规律

## 三视图之间的度量对应关系

主、俯视图长相等且对正  
俯、左视图宽相等且对应  
主、左视图高相等且平齐

三等关系

长对正  
宽相等  
高平齐

## 三视图投影规律

- V面、H面（主、俯视图）——长对正。
- V面、W面（主、左视图）——高平齐。
- H面、W面（俯、左视图）——宽相等。

## §2-2 三视图的形成及其投影规律

例：四坡屋面房屋的三面正投影

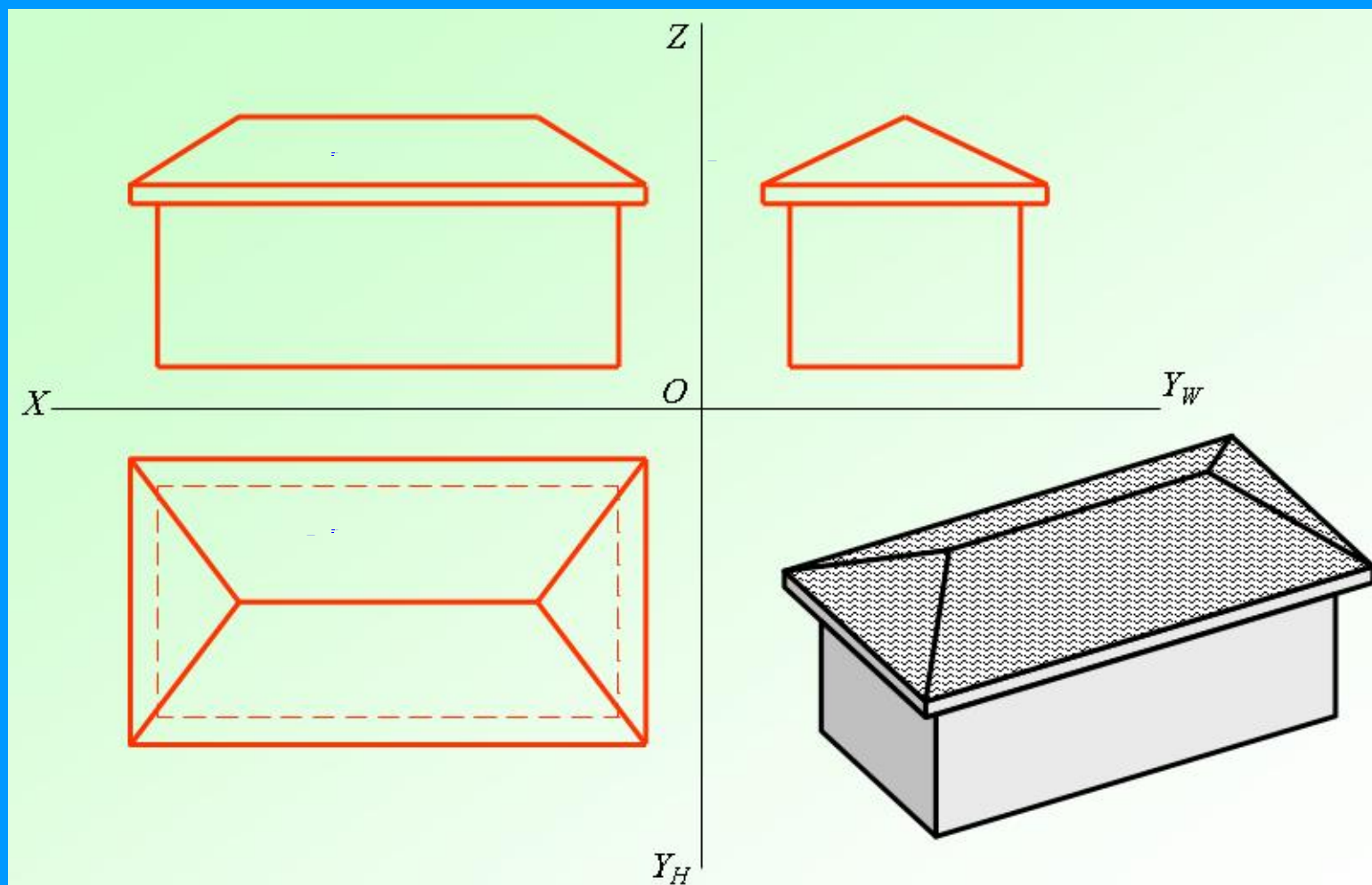

# §2-2 三视图的形成及其投影规律

## 三、三视图与物体方位对应关系

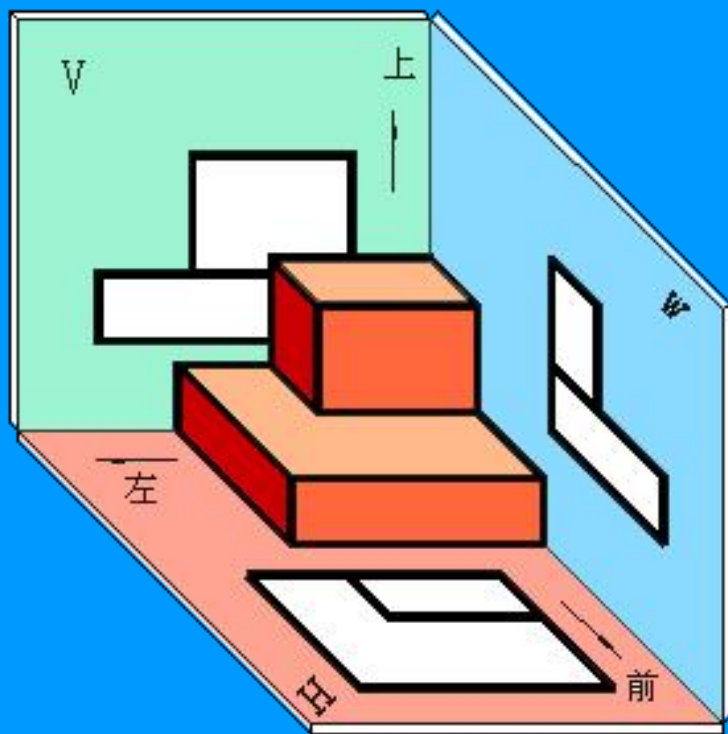

直观图

物体在空间有六个方位：

- 上、下； → 高
- 左、右； → 长
- 前、后。 → 宽

与投影规律有什么关系吗？



# §2-2 三视图的形成及其投影规律

## 三视图的方位关系

 **正面(主视图)**——反映下形体的**右**  
**前后的判定必须借助俯位左视图**

 **上面(俯视图)**——反映右形体的**后**  
**上下的判定必须借助左方位视图**

 **左面(左视图)**——反映下形体的**后**  
**左右的判定必须借助右位俯视图。**

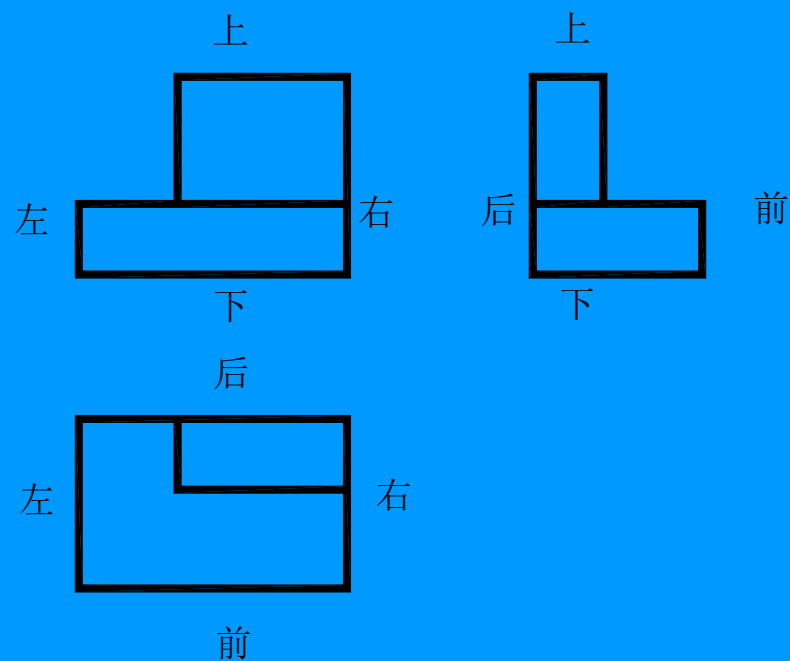

三视图的方位关系



# §2-2 三视图的形成及其投影规律

练一练

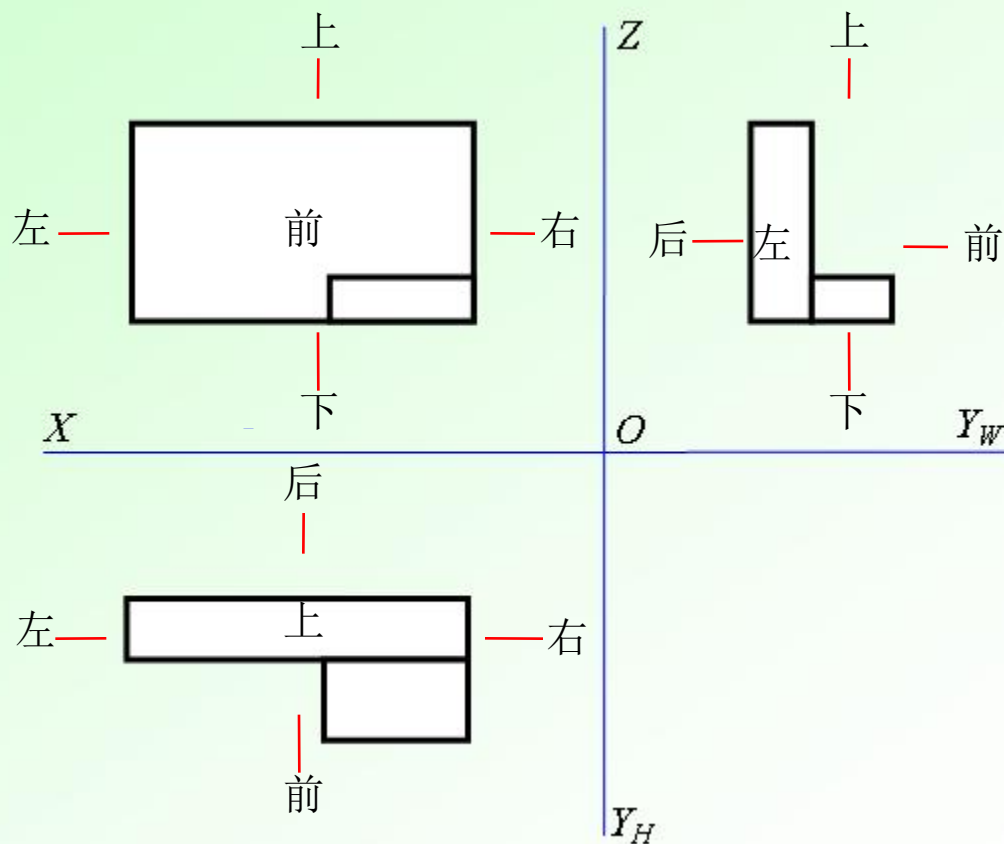
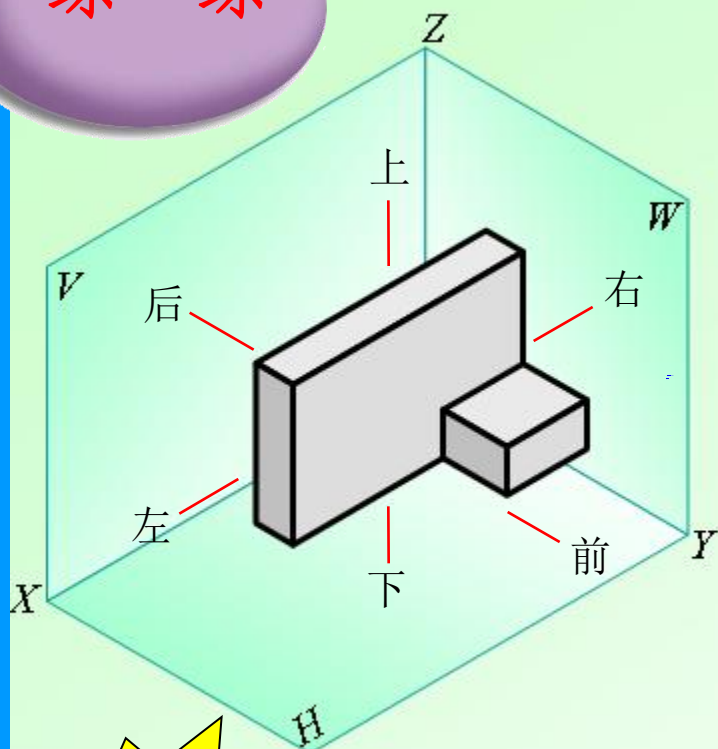

牢记!

俯、左视图中靠近主视图的一侧为物体的后方，远离的一侧为物体的前方。

# § 2-2 三视图的形成及其投影规律

## 必须说明

有些简单形体只需两个甚至一个投影图就能表达清楚。

如图中的圆管可用两个正投影表达；圆柱只需一个正投影图，利用直径符号和尺寸来表达清楚。

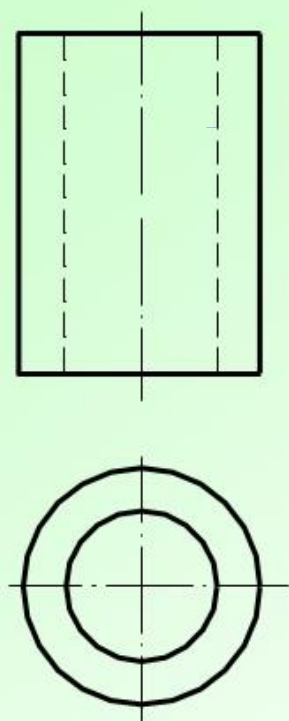

(a) 圆管

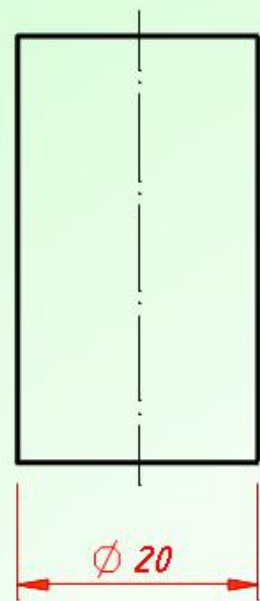

(b) 圆柱

## §2-2 三视图的形成及其投影规律

HBJS

### 四、三视图的作图与读图

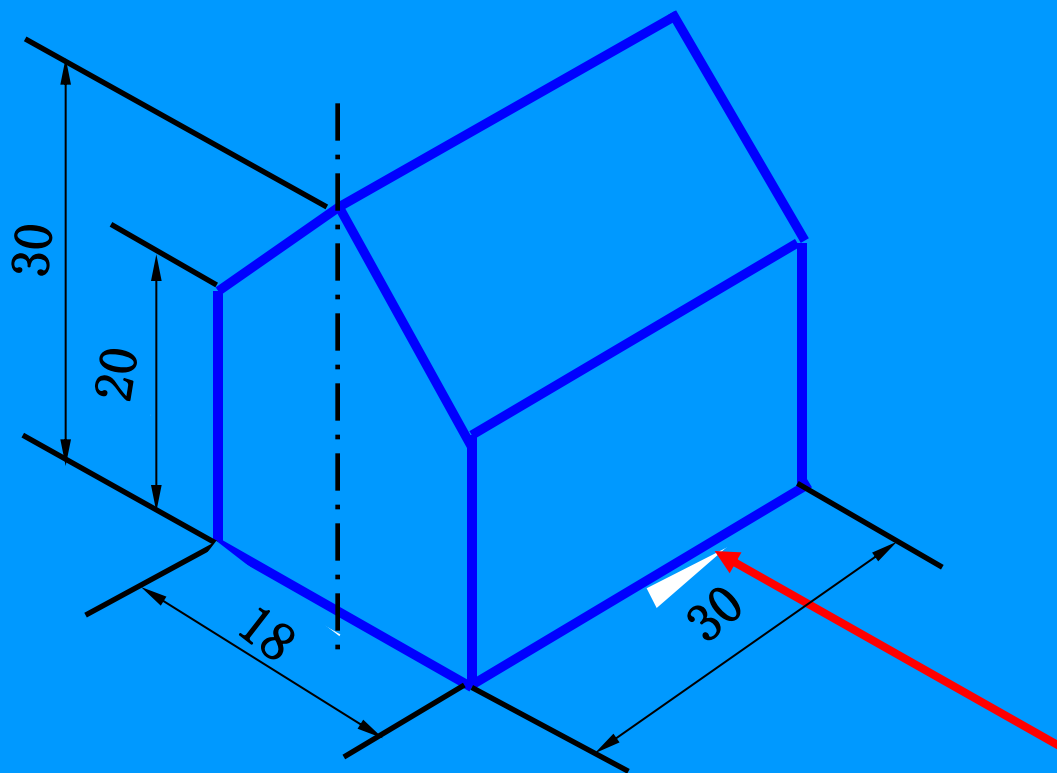

# §2-2 三视图的形成及其投影规律

作图步骤:

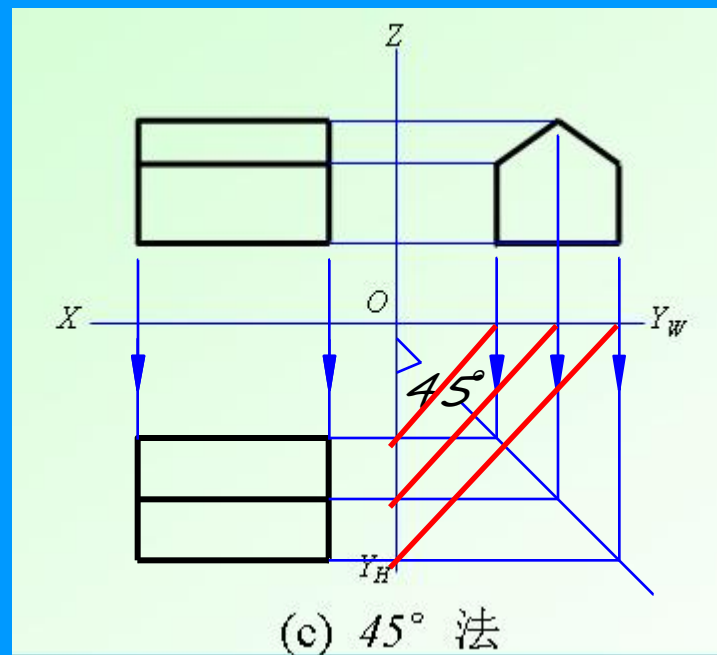
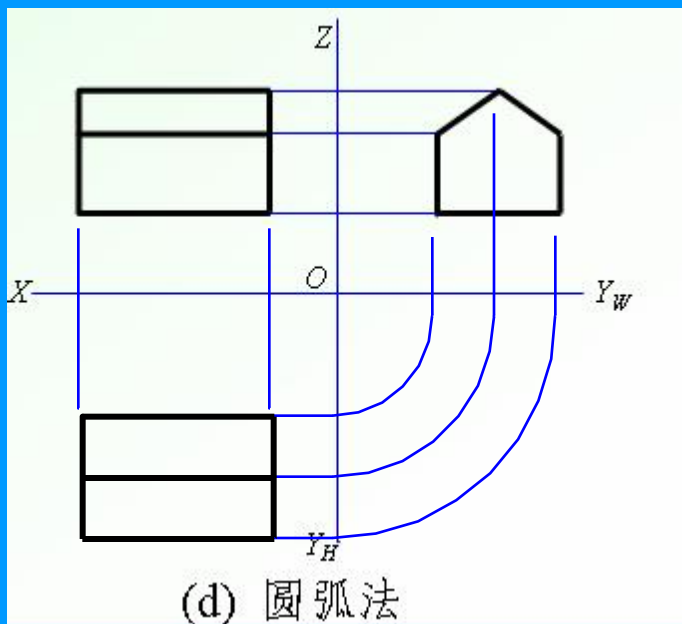

在有投影轴的情况下，宽相等的保证有三种方法。



# §2-2 三视图的形成及其投影规律

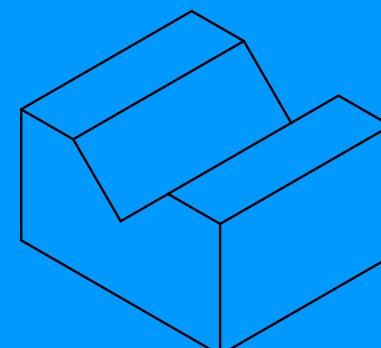
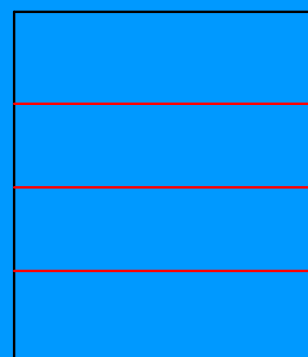
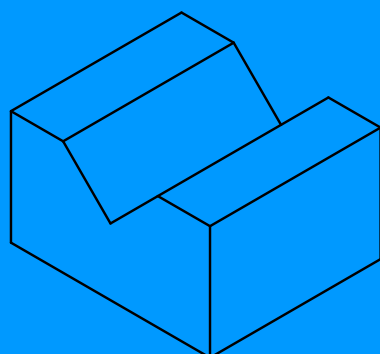
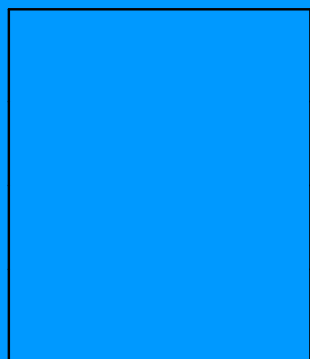
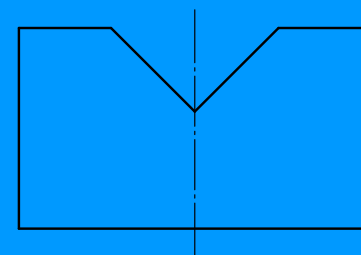
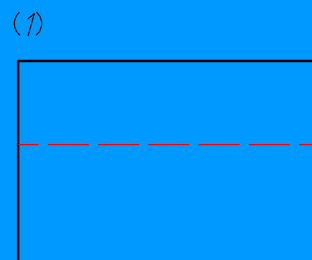
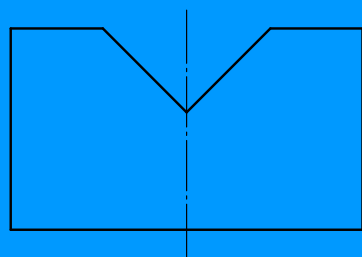
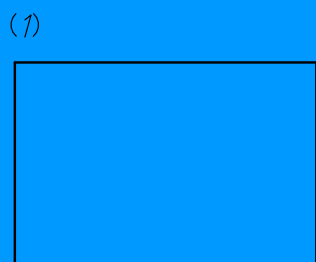

# §2-2 三视图的形成及其投影规律

(2)

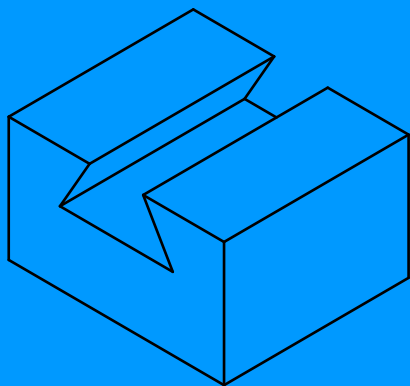
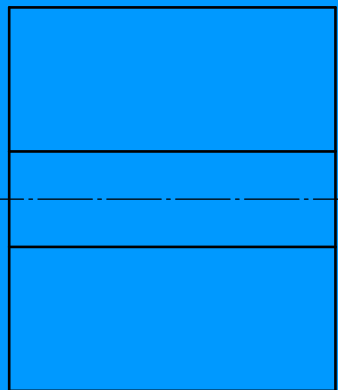
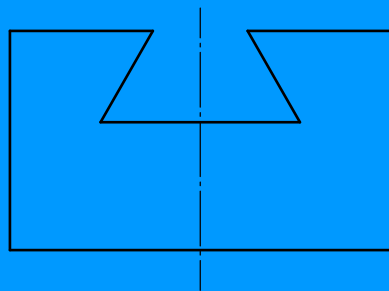
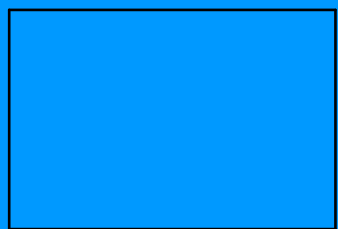

(2)

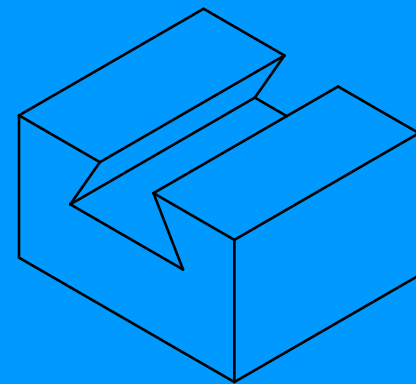
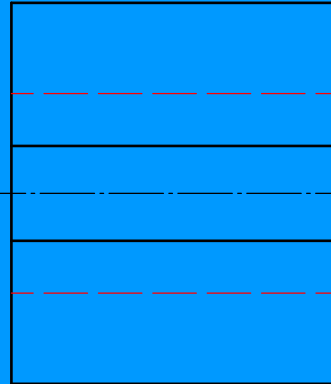
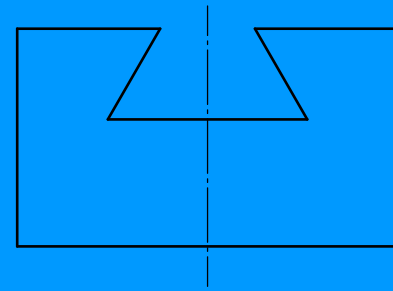
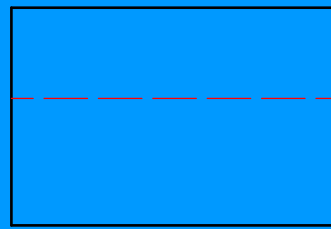

# §2-2 三视图的形成及其投影规律

(4)

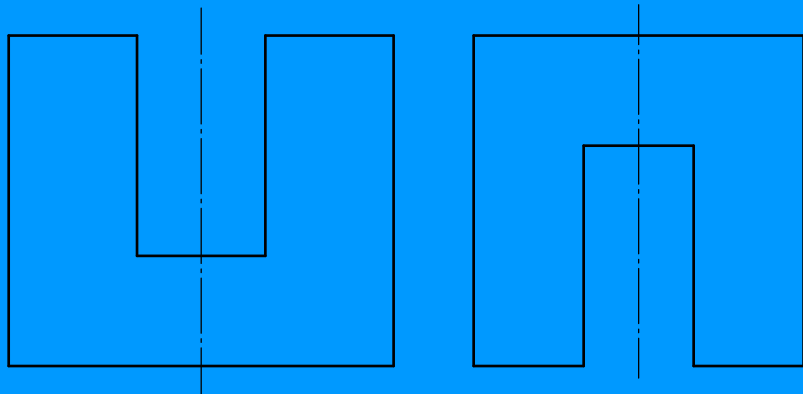



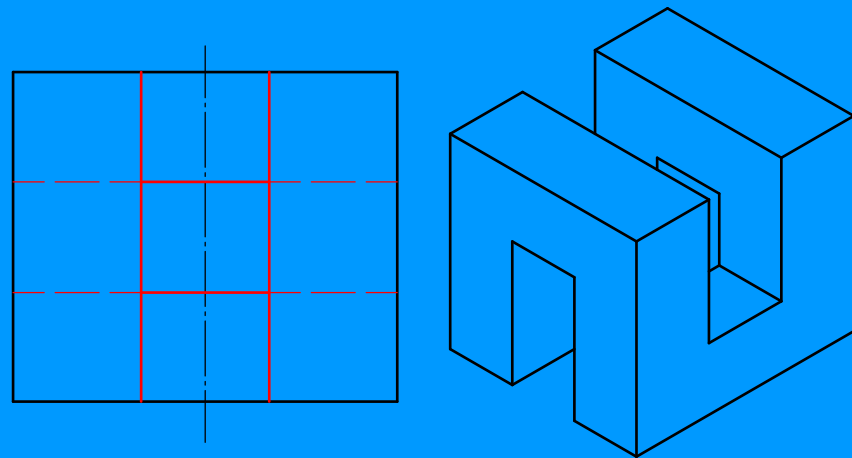
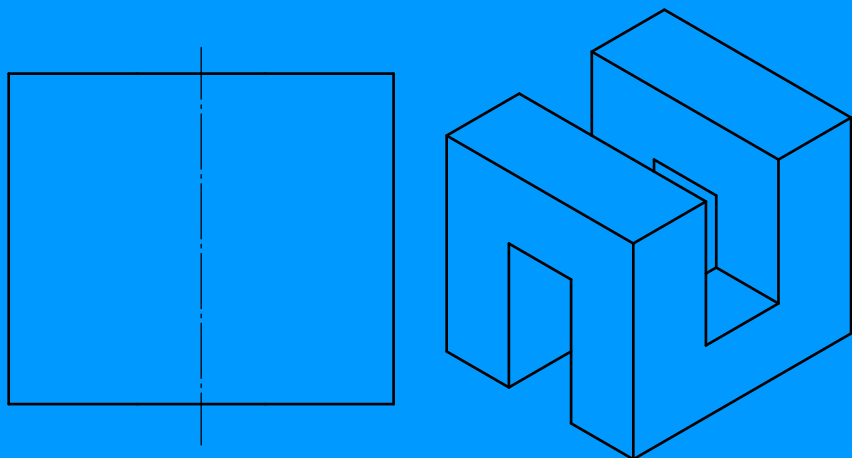
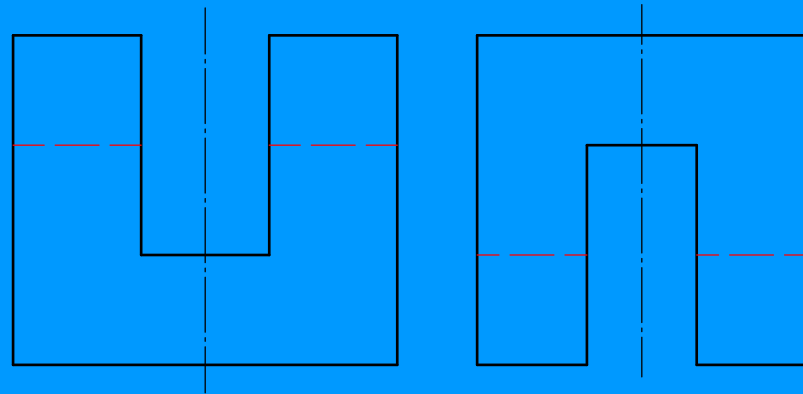

(4)

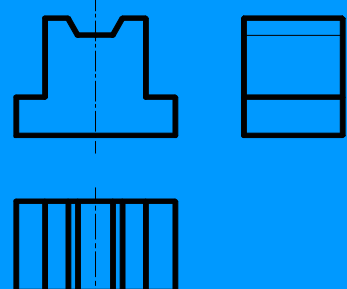
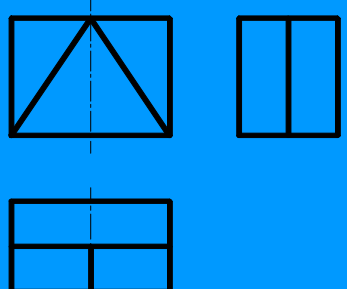
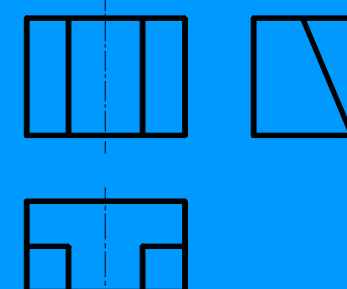
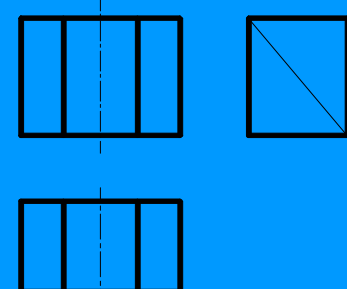
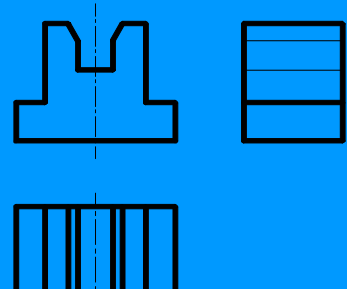
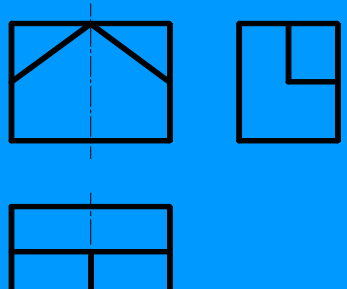
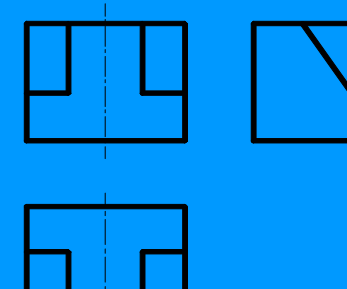
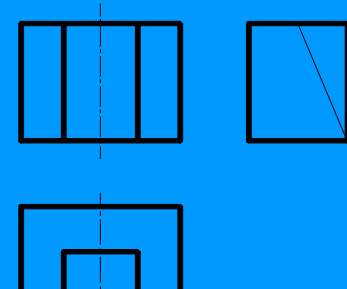

# §2-2 三视图的形成及其投影规律

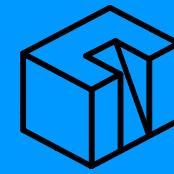
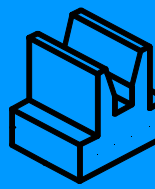
根据物体的三视图，找出对应的立体图

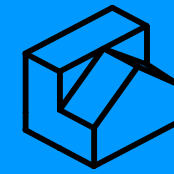
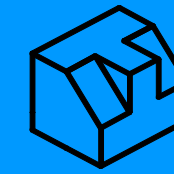
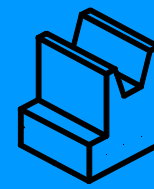
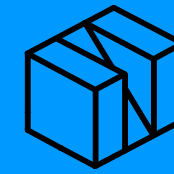
<p>(1)</p> 	<p>(2)</p> 	<p>(3)</p> 	<p>(4)</p> 				
<p>(5)</p> 	<p>(6)</p> 	<p>(7)</p> 	<p>(8)</p> 				
 <p>( )</p>	 <p>( )</p>	 <p>( )</p>	 <p>( )</p>	 <p>( )</p>	 <p>( )</p>	 <p>( )</p>	 <p>( )</p>



## §2-2 三视图的形成及其投影规律

HBJS

根据如图所示的组合体，在下列选项  
中选出正确的左视图 **B**

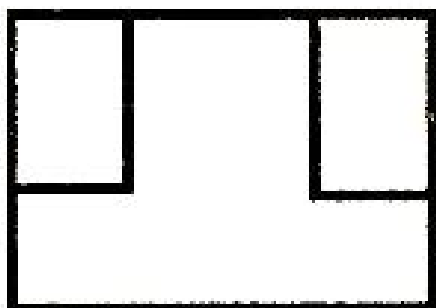

A.

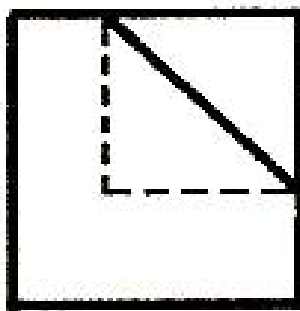

B.

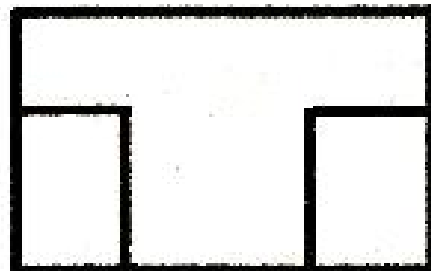

C.

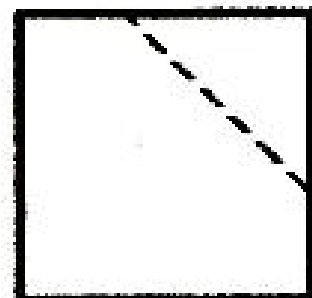

D.

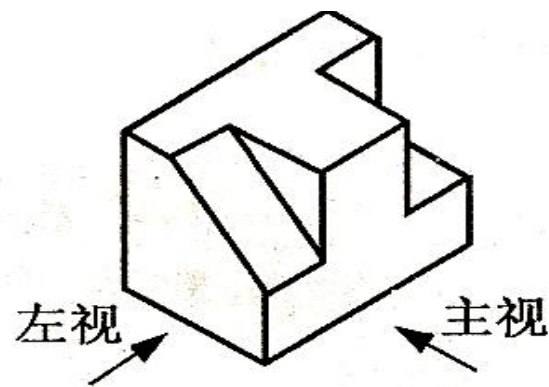

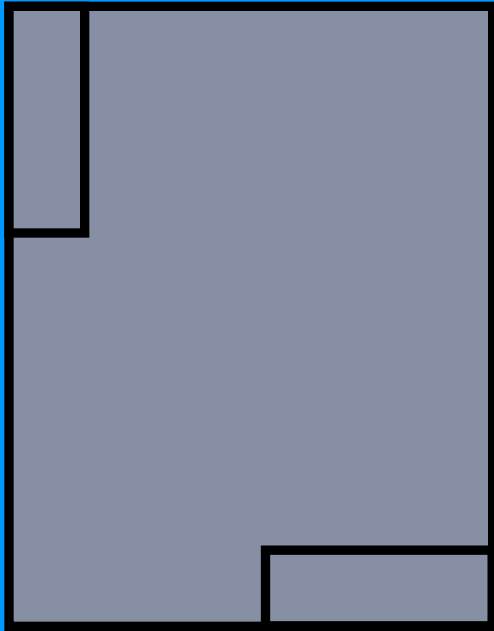
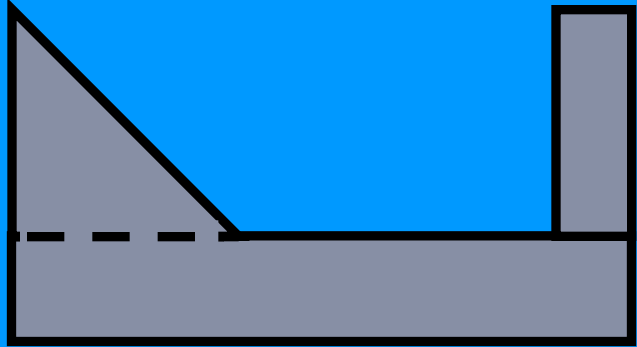
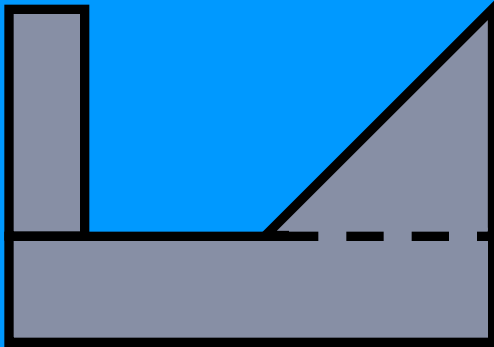
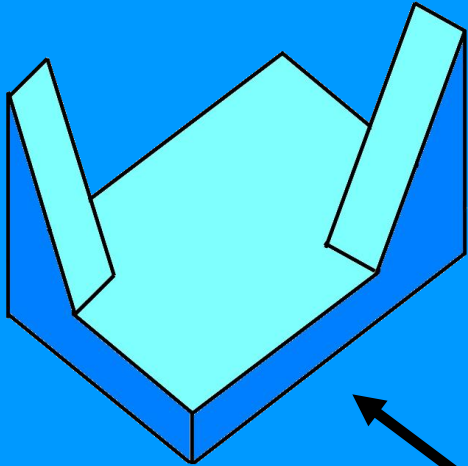

# 小结

HBJS

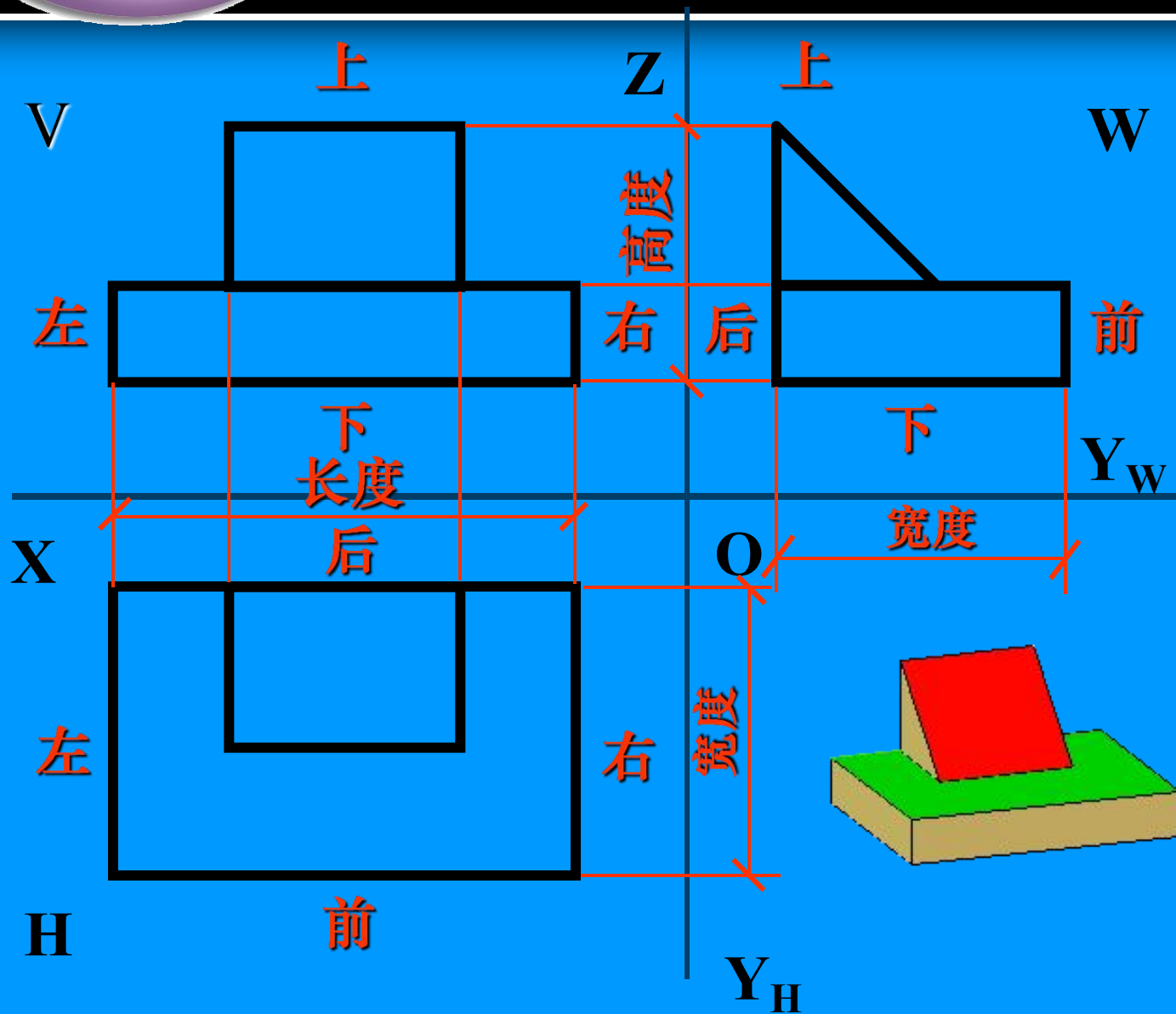

**投影规律:**

长对正  
高平齐  
宽相等

投视

**方位关系:**

上下关系  
左右关系  
前后关系

# Related Documents

HBJS

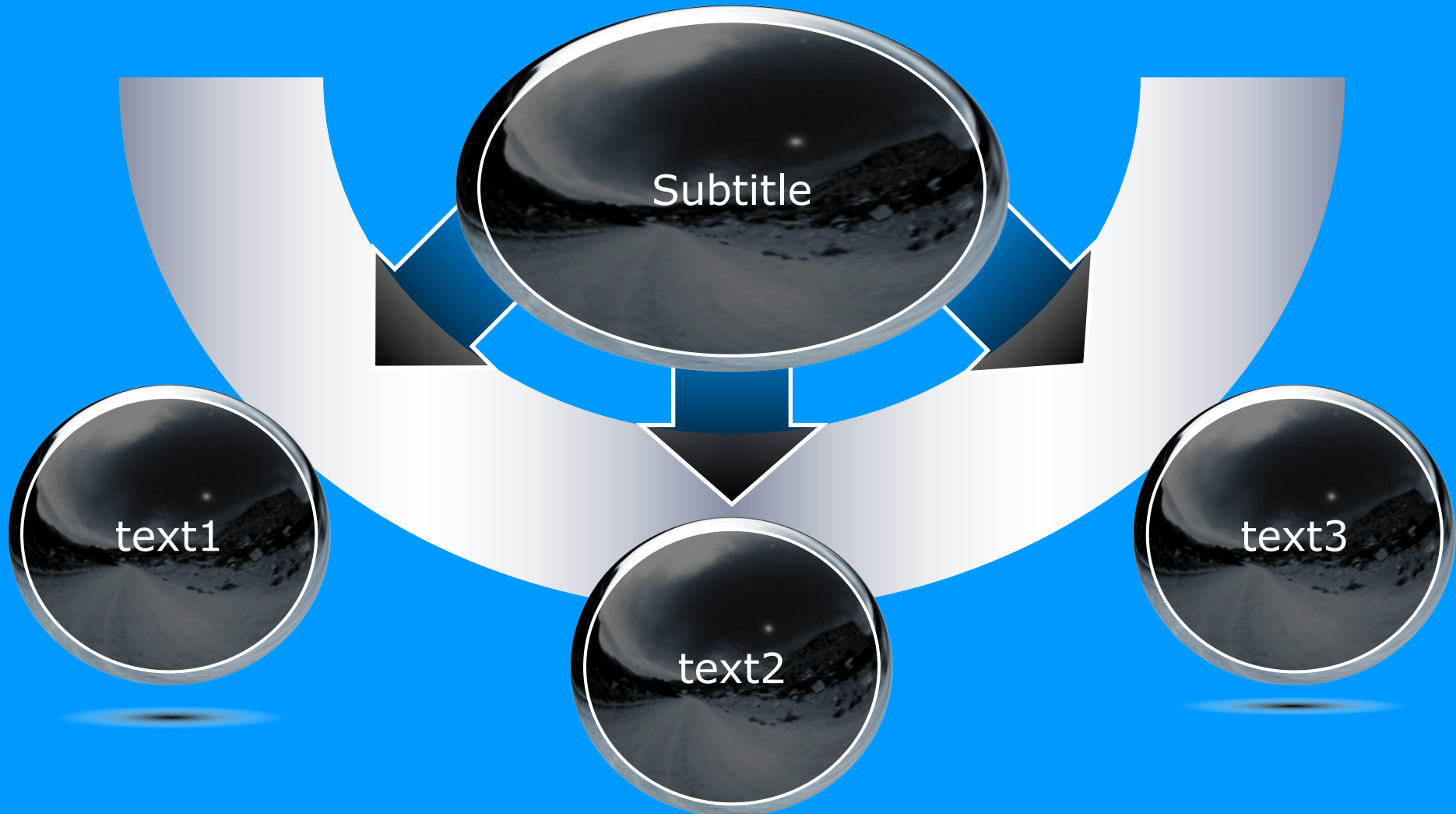

# Related Documents

HBJS

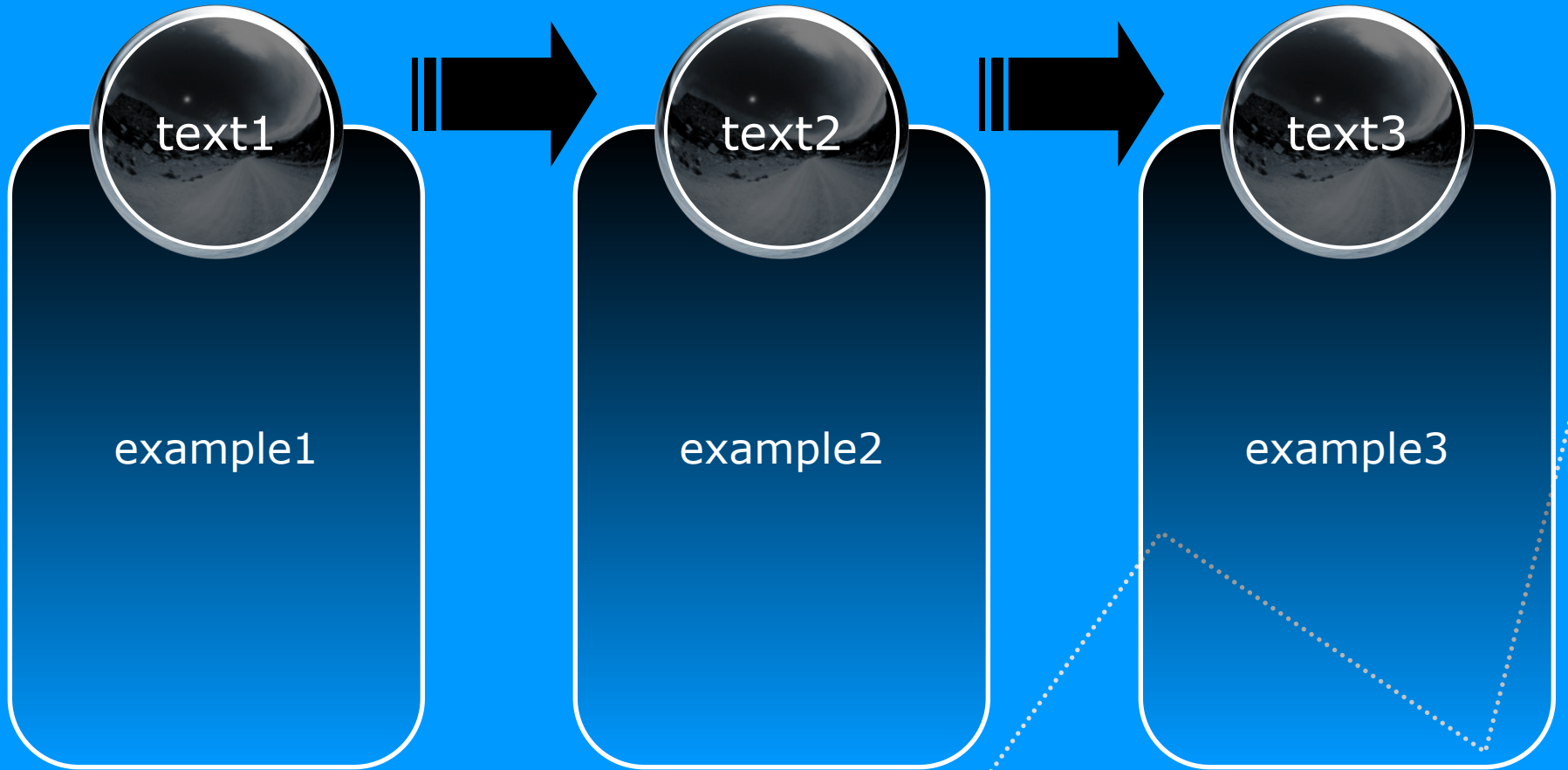

# Related Documents

HBJS

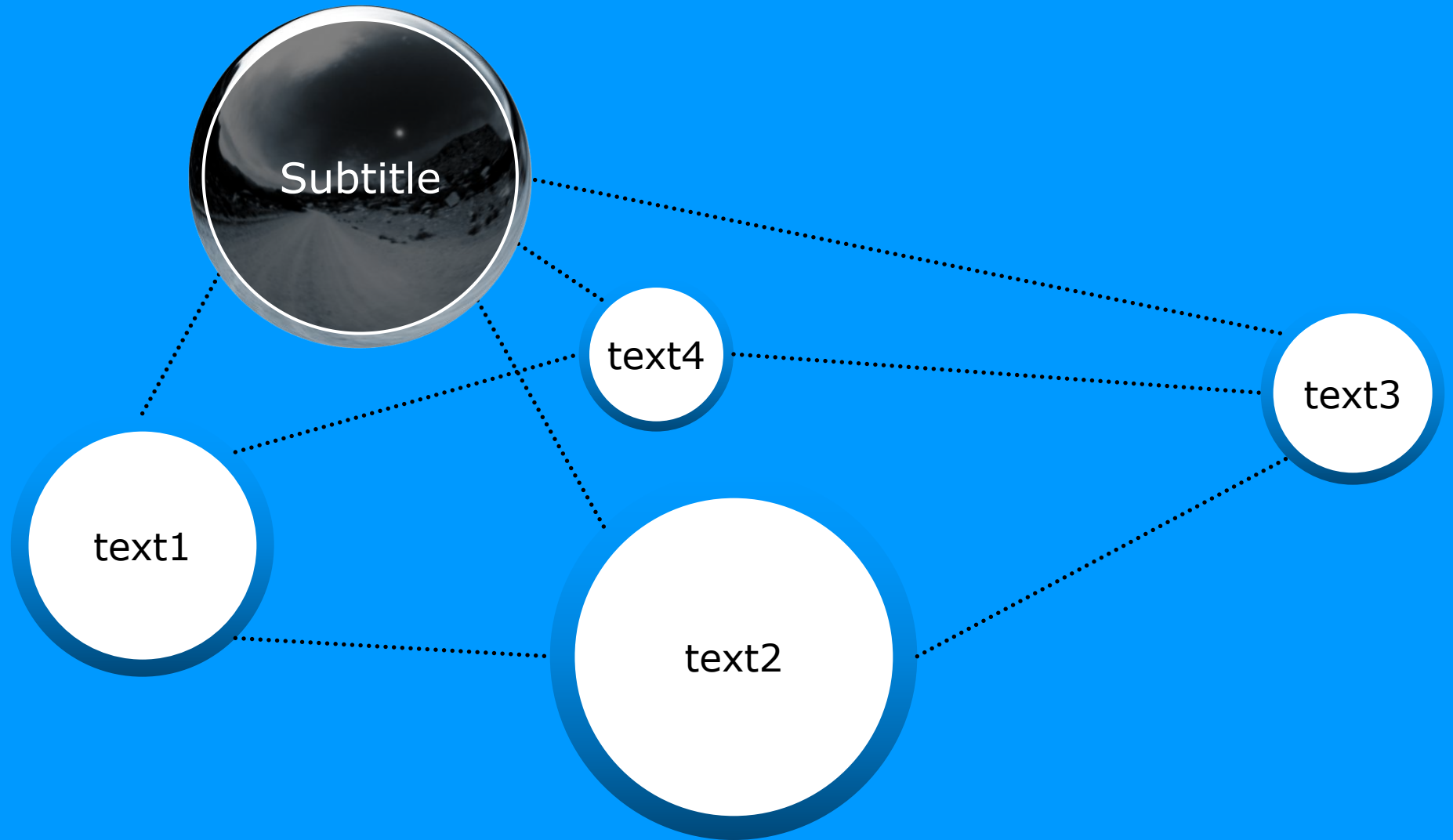

# Related Documents

HBJS

